

STAR – Roller Rail™ Systems

Runner Blocks

Runner Blocks 1824-

Slimline high long
(Size 65: slimline long)

Special version:
Zinc-iron coating, yellow chromated, in accuracy class H and preload 0.03 C.
Part numbers:
1824-.13-30

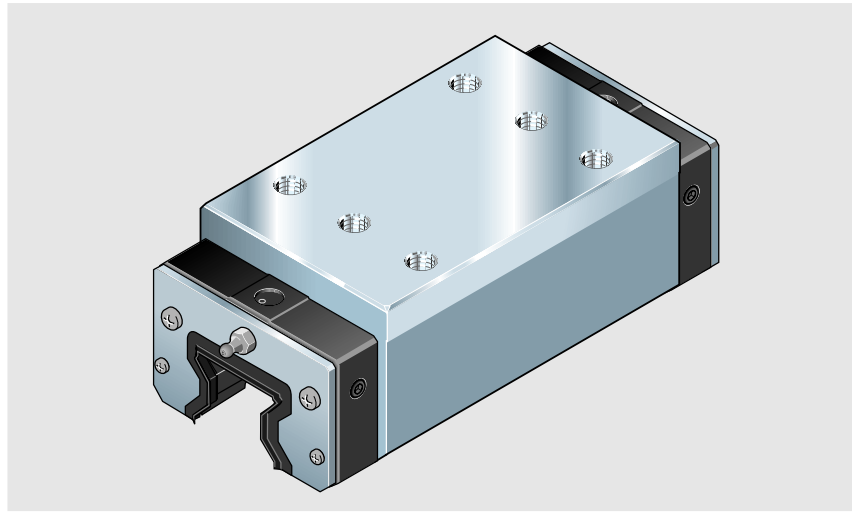

Part numbers

Size	Accuracy class	Part numbers		
		Preload 0.03 C	Preload 0.08 C	Preload 0.13 C
25	UP	1824-219-10	1824-229-10	1824-239-10
	SP	1824-211-10	1824-221-10	1824-231-10
	P	1824-212-10	1824-222-10	1824-232-10
	H	1824-213-10	1824-223-10	–
35	UP	1824-319-10	1824-329-10	1824-339-10
	SP	1824-311-10	1824-321-10	1824-331-10
	P	1824-312-10	1824-322-10	1824-332-10
	H	1824-313-10	1824-323-10	–
45	UP	1824-419-10	1824-429-10	1824-439-10
	SP	1824-411-10	1824-421-10	1824-431-10
	P	1824-412-10	1824-422-10	1824-432-10
	H	1824-413-10	1824-423-10	–
55	UP	1824-519-10	1824-529-10	1824-539-10
	SP	1824-511-10	1824-521-10	1824-531-10
	P	1824-512-10	1824-522-10	1824-532-10
	H	1824-513-10	1824-523-10	–
65	UP	1824-619-10	1824-629-10	1824-639-10
	SP	1824-611-10	1824-621-10	1824-631-10
	P	1824-612-10	1824-622-10	1824-632-10
	H	1824-613-10	1824-623-10	–

Notes on dynamic load capacities and moments

The dynamic load capacities and moments are based on 100,000 m travel.

For comparison with the 50,000 m travel sometimes applied for rail-type guideways, the figures for **C**, **M_t** and **M_L** in the table should be multiplied by 1.23.

Size	Load capacities (N)		Moments (Nm)			
	C	C ₀	M _t dyn.	M _{t0} stat.	M _L dyn.	M _{L0} stat.
25	33300	70000	432	908	420	900
35	69700	149300	1375	2953	1135	2430
45	119200	256600	2941	6331	2520	5430
55	165000	345300	4837	10122	4030	8440
65	265500	525600	9410	18630	7960	15760

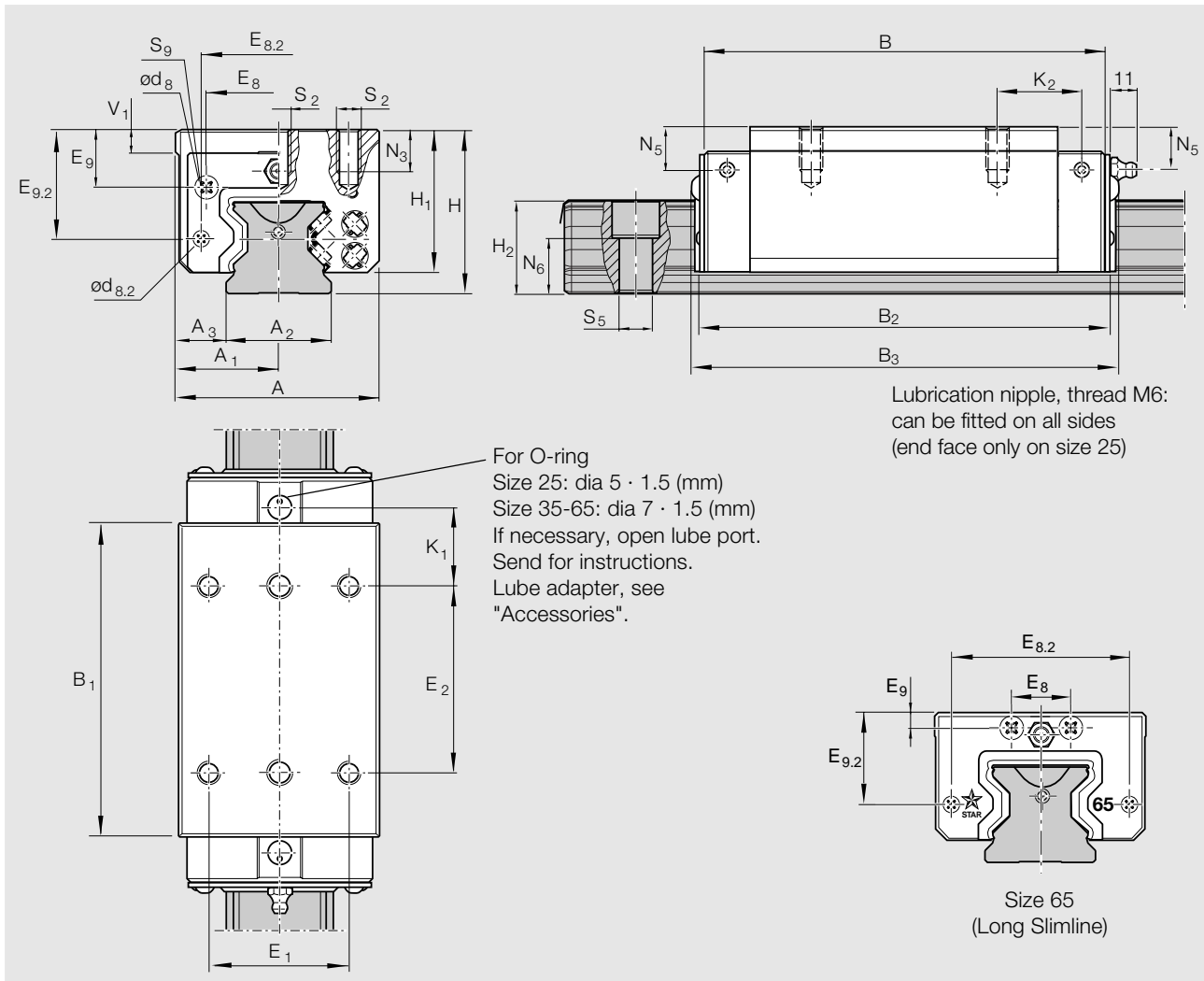

Dimensions (mm)																	
Size	A	A ₁	A ₂	A ₃	B	B ₁	B ₂	B ₃	H	H ₁	H ₂ ¹⁾	H ₂ ²⁾	V ₁	d ₈	d _{8.2}	E ₁	E ₂
25	48	24	23	12.5	109.0	81.5	111.0	115	40	34	23.55	23.40	7.5	5.7	–	35	50
35	70	35	34	18.0	138.0	103.6	140.0	145	55	48	31.10	30.80	8.0	5.7	5.2	50	72
45	86	43	45	20.5	172.5	134.0	176.5	183	70	61	39.10	38.80	10.0	7.6	5.7	60	80
55	100	50	53	23.5	205.5	162.1	209.5	216	80	68	47.85	47.55	12.0	9.5	5.7	75	95
65	126	63	63	31.5	254.0	194.0	258.5	264	90	76	58.15	57.85	15.0	–	–	76	120

¹⁾ Dimension H₂ with Rail Seal cover strip. NEW: Size 35 - 65, 0.3 mm Rail Seal

²⁾ Dimension H₂ without Rail Seal cover strip

Dimensions (mm)													Weight
Size	E ₈	E _{8.2}	E ₉	E _{9.2}	N ₃	N ₅	N ₆ ^{±0.5}	S ₂	S ₅	S ₉ ³⁾	K ₁	K ₂	(kg)
25	33.4	–	12.40	25.40	9	9.5	14.3	M6	7	M3-5 deep	20.60	–	0.9
35	50.3	56.60	20.10	36.10	13	14.0	19.4	M8	9	M3-5 deep	22.55	24.4	2.0
45	62.9	69.55	26.75	46.50	18	18.0	22.4	M10	14	M4-7 deep	33.70	36.6	4.2
55	74.2	81.60	28.95	50.75	19	19.0	28.7	M12	16	M5-8 deep	41.25	44.4	6.2
65	35.0	106.00	9.30	55.00	21	9.3	36.5	M16	18	M4-7 deep	48.80	52.0	12.0

³⁾ Thread for attachments