

# Rexroth Ball Rail Systems

## Standard Runner Blocks, Steel Version

### Runner Block 1623-

#### Slimline, long

Versions:

- Runner block without ball chain:  
for part numbers, see table
- Runner block with ball chain:  
part numbers 1623-...-22

#### Dynamic Characteristics

Speed  $v_{\max} = 5 \text{ m/s}$

Acceleration  $a_{\max} = 500 \text{ m/s}^2$

Other technical data, see chapter "General Technical Data and Calculations".

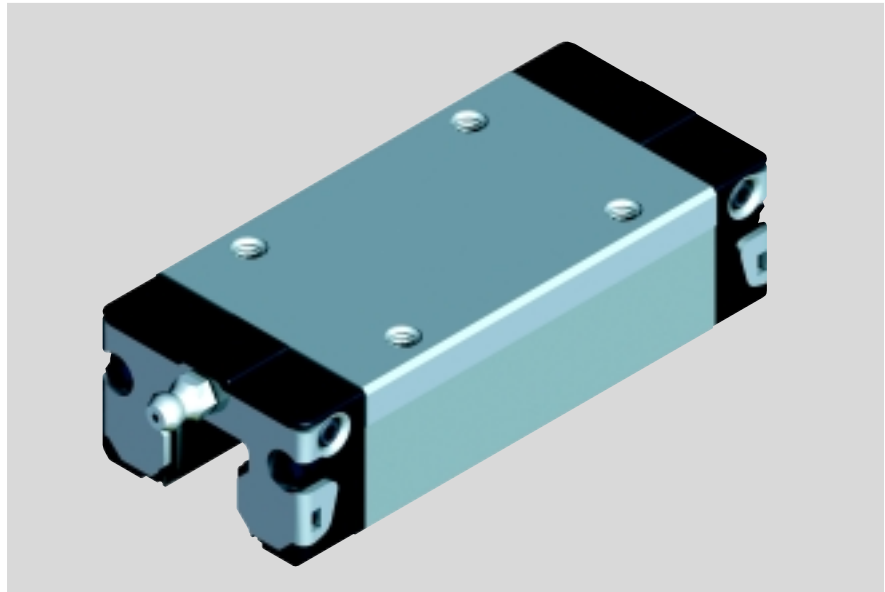

#### Part numbers

Size	Accuracy class	Part numbers for runner blocks for preload class			
		up to approx. 10 $\mu\text{m}$ clearance	Preload 0.02 C	Preload 0.08 C	Preload 0.13 C
15	N	1623-194-20	1623-114-20		
	P		1623-812-20	1623-822-20	1623-832-20
20	H	1623-893-20	1623-813-20	1623-823-20	
	N	1623-894-20	1623-814-20	1623-824-20	
25	P		1623-212-20	1623-222-20	1623-232-20
	H	1623-293-20	1623-213-20	1623-223-20	
	N	1623-294-20	1623-214-20	1623-224-20	
30	P		1623-712-20	1623-722-20	1623-732-20
	H	1623-793-20	1623-713-20	1623-723-20	
	N	1623-794-20	1623-714-20	1623-724-20	
35	P		1623-312-20	1623-322-20	1623-332-20
	H	1623-393-20	1623-313-20	1623-323-20	
	N	1623-394-20	1623-314-20	1623-324-20	
45*	P		1623-412-20	1623-422-20	1623-432-20
	H	1623-493-20	1623-413-20	1623-423-20	
	N	1623-494-20	1623-414-20	1623-424-20	

\* Under preparation

#### Note on dynamic load capacities and moments (see table)

Determination of dynamic load capacities and moments is based on a travel life of 100 000 m.

However, frequently this is determined on the basis of only 50 000 m.

In this case for comparison:  
multiply values **C**, **M<sub>t</sub>** and **M<sub>l</sub>** by 1.26  
in accordance with Rexroth table.

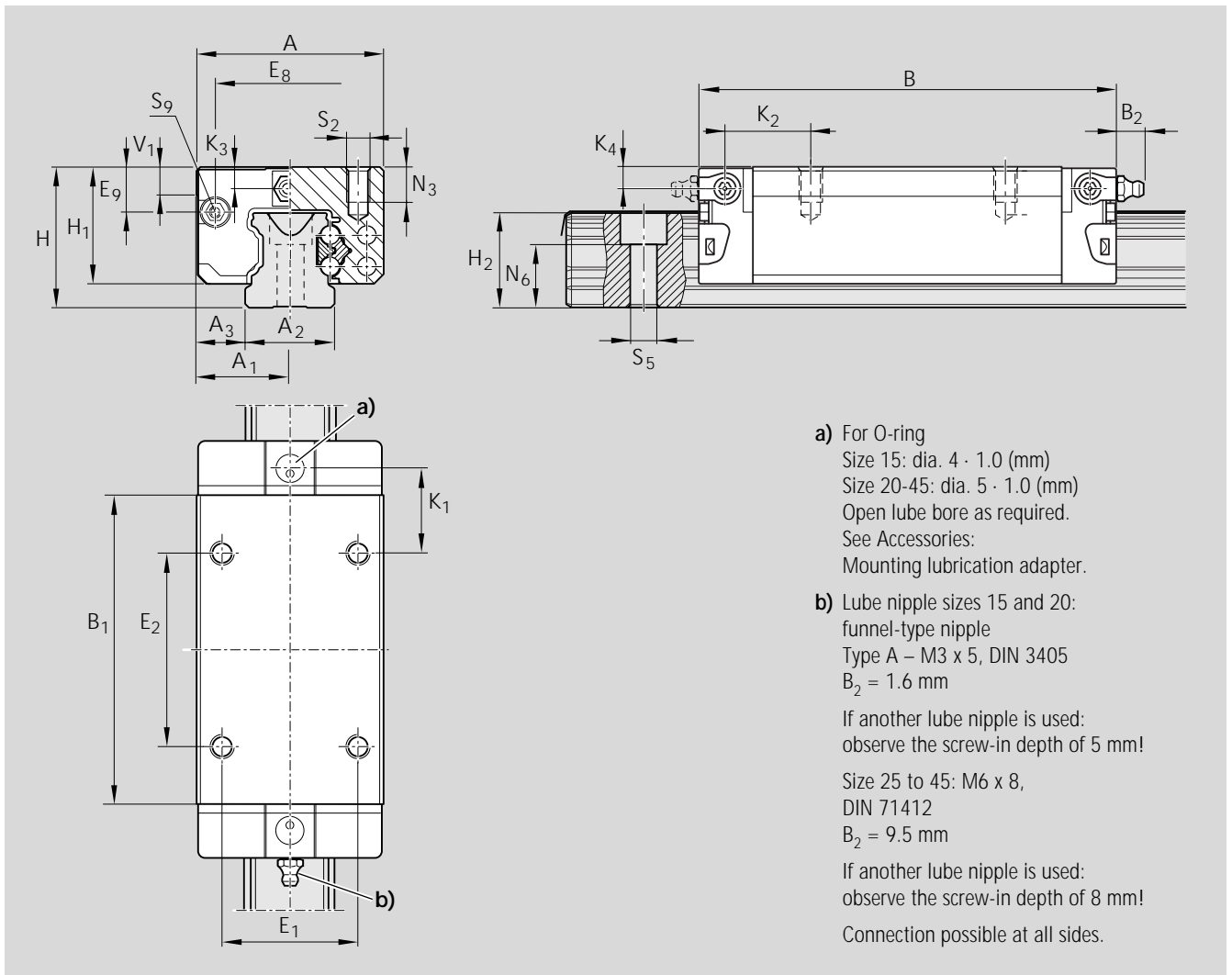

Dimensions (mm)																				
Size	A	A <sub>1</sub>	A <sub>2</sub>	A <sub>3</sub>	B	B <sub>1</sub>	H	H <sub>1</sub>	H <sub>2</sub> <sup>1)</sup>	H <sub>2</sub> <sup>2)</sup>	V <sub>1</sub>	E <sub>1</sub>	E <sub>2</sub>	E <sub>8</sub>	E <sub>9</sub>	K <sub>1</sub>	K <sub>2</sub>	K <sub>3</sub>	K <sub>4</sub>	
15	34	17	15	9.5	72.6	53.6	24	19.90	16.30	16.20	5.0	26	26	24.55	6.70	17.20	18.80	3.20	3.20	
20	44	22	20	12.0	91.0	65.6	30	25.35	20.75	20.55	6.0	32	50	32.50	7.30	14.80	14.80	3.35	3.35	
25	48	24	23	12.5	107.9	79.5	36	29.90	24.45	24.25	7.5	35	50	38.30	11.50	20.80	21.95	5.50	5.50	
30	60	30	28	16.0	119.7	89.4	42	35.35	28.55	28.35	7.0	40	60	48.40	14.60	21.00	22.70	6.05	6.05	
35	70	35	34	18.0	139.0	105.5	48	40.40	32.15	31.85	8.0	50	72	58.00	17.35	23.75	25.25	6.90	6.90	
45	86	43	45	20.5	174.1	133.5	60	50.3	40.15	39.85	10.0	60	80	69.8	20.90	35.50	37.50	8.20	8.20	

<sup>1)</sup> Dimension H<sub>2</sub> with rail seal cover strip

<sup>2)</sup> Dimension H<sub>2</sub> without rail seal cover strip

Size	N <sub>3</sub>	Dimensions (mm)					Mass (kg)	Load capacities (N) <sup>3)</sup>		Moments (Nm)			
		N <sub>6</sub> <sup>±0.5</sup>	S <sub>2</sub>	S <sub>5</sub>	S <sub>9</sub>	C dyn.		C <sub>0</sub> stat.	M <sub>t</sub> dyn.	M <sub>t0</sub> stat.	M <sub>L</sub> dyn.	M <sub>L0</sub> stat.	
15	6.0	10.3	M4	4.4	M2.5-3.5 deep	0.20	10 000	20 200	130	190	98	150	
20	7.5	13.2	M5	6.0	M3-5 deep	0.45	24 400	35 200	310	450	225	330	
25	9.0	15.2	M6	7.0	M3-5 deep	0.65	30 400	45 500	430	650	345	510	
30	12.0	17.0	M8	9.0	M3-5 deep	1.10	40 000	57 800	690	1 000	495	715	
35	13.0	20.5	M8	9.0	M3-5 deep	1.70	55 600	81 000	1 200	1 740	830	1 215	
45	18.0	23.5	M10	14.0	M4-7 deep	3.20	90 400	128 500	2 440	3 470	1 700	2 425	

<sup>3)</sup> Load capacities for version without ball chain. Load capacities for version without ball chain, see Product Overview with Load Capacities.

# Rexroth Ball Rail Systems

## Standard Runner Blocks, Steel Version

### Runner Block 1623-

Slimline, long

#### Dynamic Characteristics

Speed  $v_{\max} = 3 \text{ m/s}$

Acceleration  $a_{\max} = 250 \text{ m/s}^2$

Other technical data, see chapter "General Technical Data and Calculations".

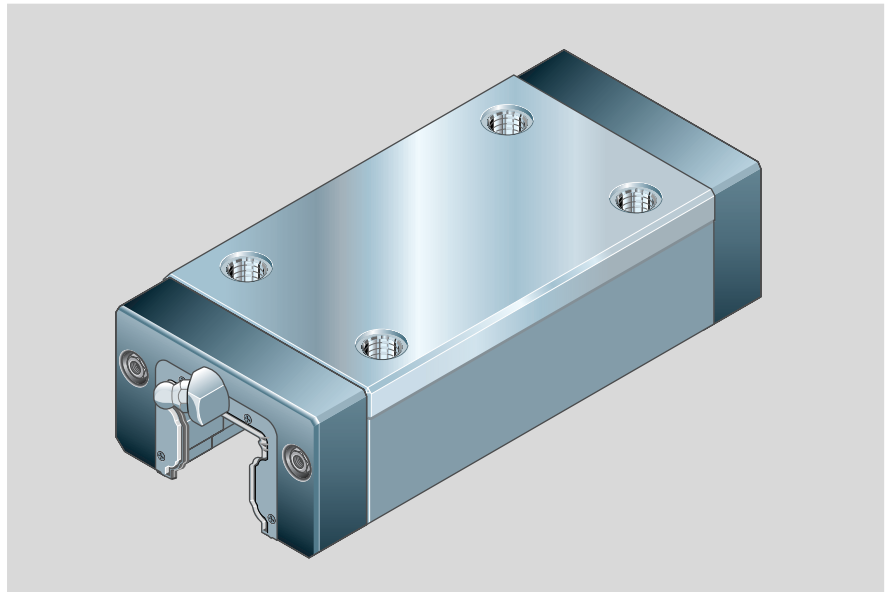

#### Part numbers

Size	Accuracy class	Part numbers for runner blocks for preload class			
		up to approx. 10 $\mu\text{m}$ clearance	Preload 0.02 C	Preload 0.08 C	Preload 0.13 C
45*	P		1623-412-10	1623-422-10	1623-432-10
	H	1623-493-10	1623-413-10	1623-423-10	
	N	1623-494-10	1623-414-10	1623-424-10	
55	P		1623-512-10	1623-522-10	1623-532-10
	H	1623-593-10	1623-513-10	1623-523-10	
	N	1623-594-10	1623-514-10	1623-524-10	
65	P		1623-612-10	1623-622-10	1623-632-10
	H	1623-693-10	1623-613-10	1623-623-10	
	N	1623-694-10	1623-614-10	1623-624-10	

\* Phased-out model

#### Note on dynamic load capacities and moments (see table)

Determination of dynamic load capacities and moments is based on a travel life of 100 000 m.

However, frequently this is determined on the basis of only 50 000 m.

In this case for comparison: multiply values **C**, **M<sub>t</sub>** and **M<sub>L</sub>** by 1.26 in accordance with Rexroth table.

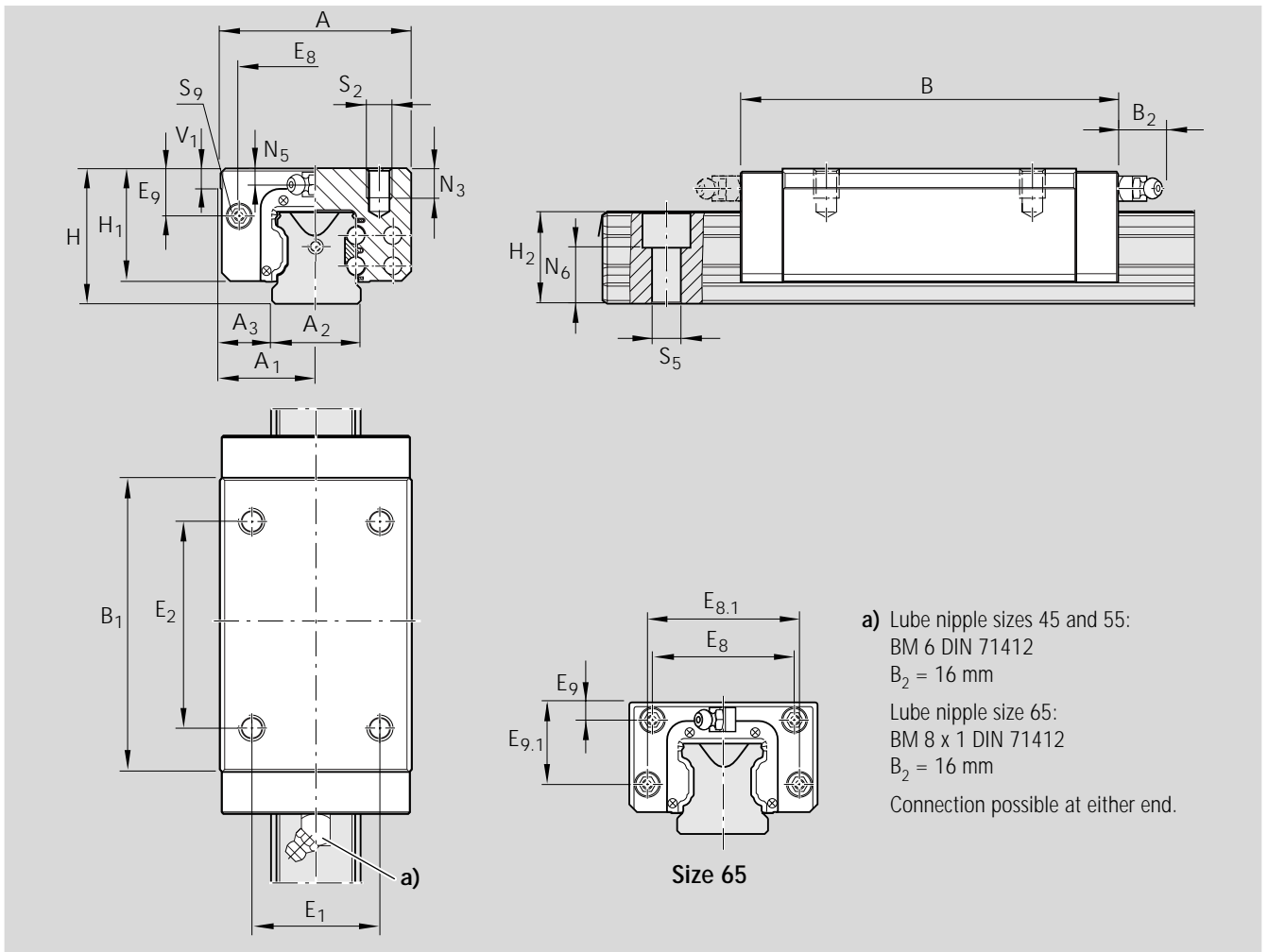

Size	Dimensions (mm)																	
	A	A <sub>1</sub>	A <sub>2</sub>	A <sub>3</sub>	B	B <sub>1</sub>	H	H <sub>1</sub>	H <sub>2</sub> <sup>1)</sup>	H <sub>2</sub> <sup>2)</sup>	V <sub>1</sub>	E <sub>1</sub>	E <sub>2</sub>	E <sub>8</sub>	E <sub>8.1</sub>	E <sub>9</sub>	E <sub>9.1</sub>	N <sub>3</sub>
45	86	43	45	20.5	170.0	133.5	60	50.0	40.15	39.85	10.0	60	80	69.8		20.9		18.0
55	100	50	53	23.5	200.0	155.5	70	57.0	48.15	47.85	12.0	75	95	80.0		22.3		19.0
65	126	63	63	31.5	243.0	194.6	90	76.0	60.15	59.85	15.0	76	120	76.0	100	11.0	53.5	21.0

<sup>1)</sup> Dimension H<sub>2</sub> with rail seal cover strip

<sup>2)</sup> Dimension H<sub>2</sub> without rail seal cover strip

Size	Dimensions (mm)						Mass (kg)	Load capacities (N)				Moments (Nm)			
	N <sub>5</sub>	N <sub>6</sub> <sup>±0.5</sup>	S <sub>2</sub>	S <sub>5</sub>	S <sub>9</sub>	C		M <sub>t</sub>		M <sub>L</sub>		M <sub>L0</sub>			
						dyn.		stat.	dyn.	stat.	dyn.	stat.			
45	8.0	23.5		M10	14.0	M4-7 deep	3.1	90 400	128 500	2 440	3 470	1 700	2 425		
55	9.0	29.2		M12	16.0	M5-8 deep	4.8	124 200	170 000	3 950	5 400	2 630	3 600		
65	16.0	38.5		M16	18.0	M4-7 deep	9.8	163 000	289 000	6 440	11 420	4 620	8 190		