

SFS - W SERVOFLEX (Available by special order)

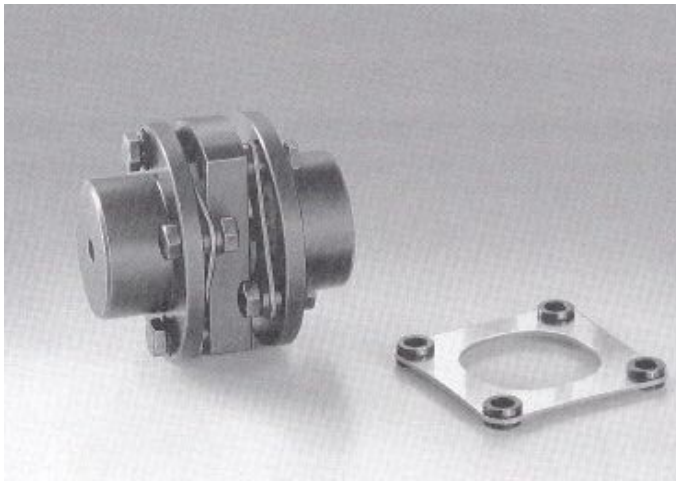

➤ **Large permissible misalignment, easy installation**

Two elements are used through a spacer plate and large misalignment in a small space can be allowed. Therefore, centering work can be reduced.

➤ **Flexibility in bending and axial directions**

Two elements are mounted to minimize thermal expansions of driving and driven shafts and internal force due to deformation of the support after many hours' operation. A long equipment life can be expected.

Specification

Model	SFS-05W	SFS-06W	SFS-08W	SFS-09W	SFS-10W	SFS-12W	SFS-14W	
Permissible Torque [N·m]	20	40	80	180	250	450	800	
Maximum Speed [r/min]	10000	8000	6800	6000	5200	4400	3800	
Torsional Spring Constant [N·m/rad]	8×10^3	14×10^3	41×10^3	85×10^3	125×10^3	215×10^3	390×10^3	
Axial Spring Constant [N/mm]	21	22	30	61	80	98	156	
Inertia [kg·m ²]	0.14×10^{-3}	0.41×10^{-3}	1.1×10^{-3}	2.2×10^{-3}	3.6×10^{-3}	9.2×10^{-3}	15×10^{-3}	
Maximum Permissible misalignment	Parallel offset [mm]	± 0.2	± 0.3	± 0.3	± 0.5	± 0.5	± 0.6	± 0.7
	Angular misalignment [°]	1(One side)	1(One side)	1(One side)	1(One side)	1(One side)	1(One side)	1(One side)
	Axial Displacement [mm]	± 1.2	± 1.6	± 2.0	± 2.4	± 2.8	± 3.2	± 3.6
Mass [g]	0.4	0.7	1.3	2.1	2.8	4.9	7.1	

• Values marked are those when bore diameter is maximum.

■ Ordering Information : Specify

SFS - W

Design Types and Dimensions

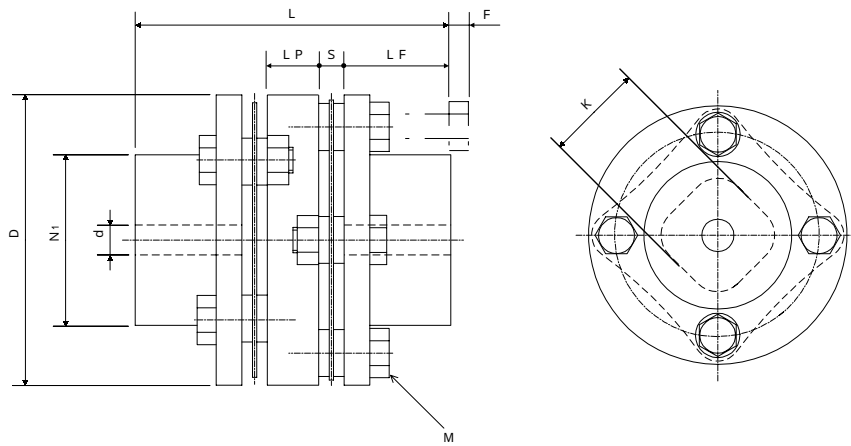

Model	SFS-05W	SFS-06W	SFS-08W	SFS-09W	SFS-10W	SFS-12W	SFS-14W	
d	Pilot Bore	7	7	12	12	20	20	20
	Min	8	8	14	14	22	22	22
	Max	20	25	35	38	42	50	60
D	56	68	82	94	104	126	144	
N	32	40	54	58	68	78	88	
L	58	74	84	98	110	127	144	
LF	20	25	30	30	35	40	45	
LP	8	12	12	22	20	25	30	
S	5	6	6	8	10	11	12	
F	4	3	2	12	7	10	15	
K	24	30	38	42	48	54	61	
M	8-M5 x 15	8-M6 x 18	8-M6 x 20	8-M8 x 27	8-M8 x 27	8-M10 x 32	8-M12 x 38	

- Prepared bores are drilled bores.
- Couplings with a built-in shaft fixing mechanism can be supplied upon request.