

UNFINISHED SHAFT ENDS

Screw shaft diameter $\phi 15$, Lead 10 (U nut)

(Unit : mm)

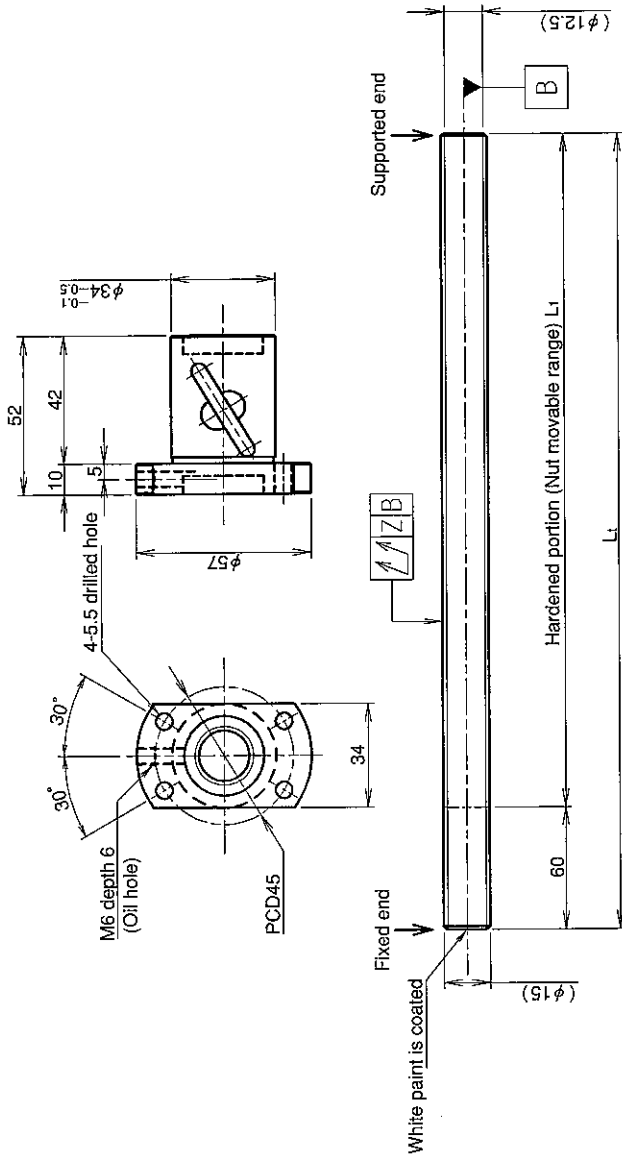

Ball screw specifications

Screw shaft dia.	15	Basic dynamic load rating	5100N
Lead	10	Basic static load rating	10500N
Thread direction	Right-hand	Lubricant	Alvania Grease No.2
Number of circuits	2.5turn	Surface treatment	Phosphate coating
Ball diameter	3.175		

Table of optional specifications for each model

Additional machining of shaft end	Surface treatment (Note 1)	Direction of grease	Direction of nut removal	Wiper
○	○	○	○	○

(Note 1) The above-mentioned surface treatment is LD treatment (coating thickness : 1 to 2 μ m).

Model No.	Axial clearance	L ₁	Z	Wiper
GY1510DS-HULR-0600A	~0.100	540	0.140	Lip seal
GY1510DS-HULR-1200A		1140	0.400	

Notation of standard rolled ball screw

- Standard length shaft without end machining (Matched screw shaft and nut)
GY1510DS-HULR-□□□□X□□□□□-CAY
- Nut only without screw shaft
GY1510DS-HULR
- Screw shaft only without end machining
GY1510ZZ-ZZZZ-□□□□□□□□□□
- With end machining specified on your drawing (Matched screw shaft and nut)
GY1510DS-HULR-□□□□X□□□□□-CAY
- With end machining specified on your drawing (Screw shaft only)
GY1510ZZ-ZZZZ-□□□□Y□□□□□-CAY

Overall length Thread length

SHAFT END FINISH ORDERING SHEET

Screw shaft diameter $\phi 15$, Lead 10 (U nut)

(Unit : mm)

GY1510DS-HULR- X -CAY

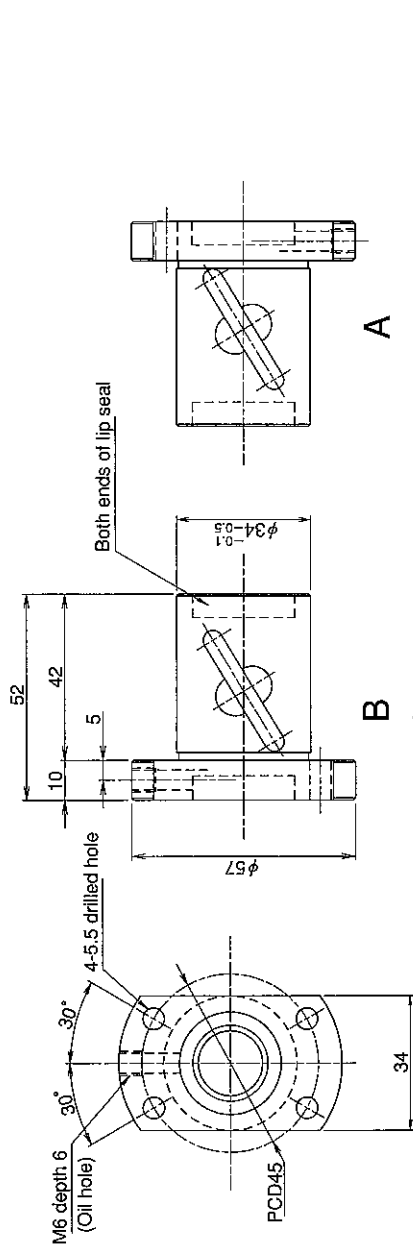

Select the orientation of nut flange by circling A or B.
No marking means "B" orientation as default.

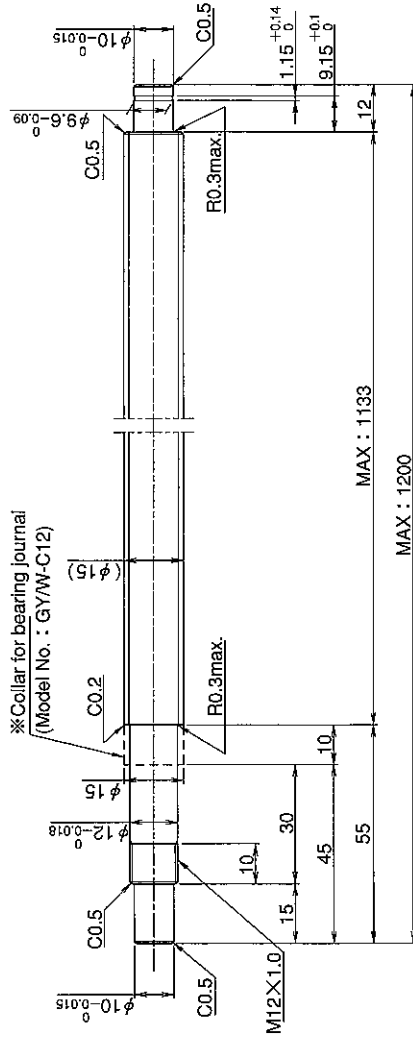

※ Please place an order for collar separately.

Applicable Support Unit

Direct mount : BUK-12A (Fixed end unit) + Supported end unit) Refer to Page.405

Circle flange : BUM-12 (Fixed end unit) + Supported end bearing) Refer to Page.412

Company Name	
Telephone	Name of Person in Charge
Company Address	